

**TCM**



**DIESEL POWERED  
PNEUMATIC TIRE TRUCKS**

**6-10ton**

FD60 / FD70 / FD80 / FD100

# Our new diesel engine runs cleaner and stronger!

The TCM FD60 to FD100 forklift trucks have been substantially upgraded to be more powerful, yet eco-friendly workhorses with a variety of state-of-the-art features.

They include electronically-controlled diesel engine which meets the emission levels required in the U.S. EPA Tier 3 and EU Stage IIIA regulations. The new series offer both more eco-friendliness and higher productivity, to meet the load handling challenges of today as well as tomorrow.

**ECOLOGY**

**COMFORT**

**SAFETY**

**ECONOMY**



**FD60 / FD70 / FD80 / FD100**



# ECO-FRIENDLINESS

Quest for greater eco-friendliness with a greener diesel engine

## Greener than ever

This environmentally friendly diesel engine emits substantially less nitrogen oxides (NOx) and particulate matter (PM).

\* Diesel engine is equipped with a turbocharger and an intercooler  
The rated output has been increased substantially to ensure the highest output in these truck classes, for higher productivity.  
\* The rated speed is as low as 2,000 rpm, making this engine more durable than ever.

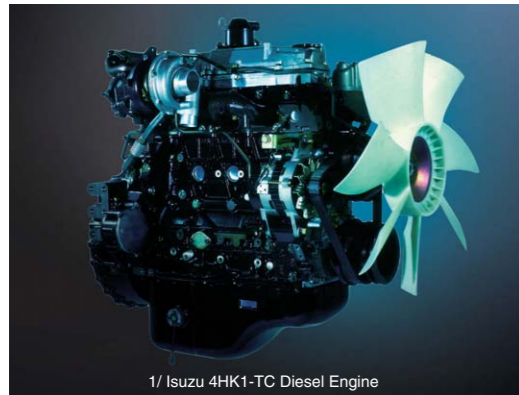

1/ Isuzu 4HK1-TC Diesel Engine

Total displacement:	Rated output:	Max. torque:
<b>5.193cc</b>	<b>87.0kW at 2,000rpm</b> (Gross)	<b>486.7N-m at 1,500rpm</b> (Gross)

Use of advanced engine technologies: common rail fuel injection system and electronic all speed control.

Fuel consumption has been reduced **8%**  
(source: internal data)

### Common rail fuel injection system

The common rail fuel injection system uses a single fuel pump to put the fuel under extremely high pressure. Then, the fuel is distributed through the common rail to each cylinder under high and consistent pressure. The injector for each cylinder is electronically controlled, to deliver precisely the optimal amount of fuel at the perfect time, to suit the engine's immediate operating conditions. Optimized fuel combustion substantially reduces the amount of pollutants in the exhaust gas. It also helps improve fuel economy and reduces engine vibration.

Note: Use only JIS K-2204 diesel fuel or equivalent; otherwise the engine may be damaged and fail.

The use of a common rail equalizes the fuel injection pressure at all cylinders.

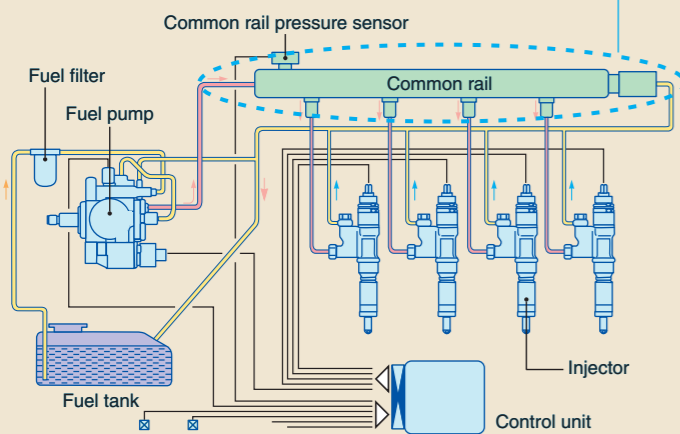

### Cooled exhaust gas recirculation (EGR) system

Cooled exhaust gas recirculation (EGR) is a technique for reducing nitrogen oxide (NOx) emissions by mixing a portion of an engine's exhaust gas with the intake air to reduce the concentration of oxygen in the combustion chamber. This helps reduce the temperature during combustion, which lowers the formation of NOx. In addition, the EGR cooler reduces the exhaust temperature, while the fuel to air ratio control system uses a feedback loop to control the fuel/air mixture supplied to the engine, reducing the formation of NOx even more and improving fuel economy.

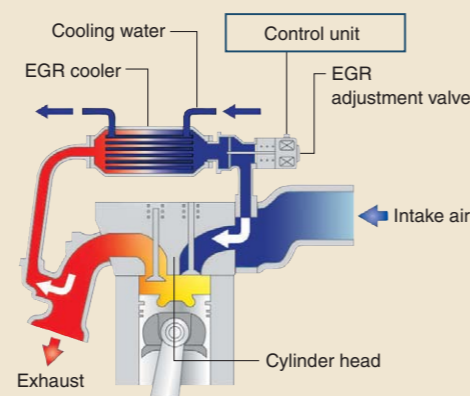

The EGR system cools part of the exhaust and mixes it with the intake air to achieve more efficient fuel combustion when the engine is running at low speeds.

# OPERATOR COMFORT

Quest for better work efficiency through advanced features

## Easier operation



### 1 New, easy-to-read instrument panel

The new type of instrument panel is easy to read and simple to understand. The indicators are brightly lit with long-life LEDs.



### 6 Electric directional control lever

The electric directional control lever makes it easy to change the direction of travel.



### 2 The light switch is combined in the turn signal lever

The light switch has been integrated with the turn signal lever for easier operation.



### 3 Auto-return turn signal lever

The turn signal lever returns automatically to neutral when the steering wheel is returned to the straight-ahead position.

### 4 Fully-hydraulic power steering

Fully-hydraulic power steering makes it possible to turn the wheels while the truck is at a complete stop.

### 5 Automatic correction of steering wheel knob deviation

Fully-hydraulic power steering systems unintentionally allow the steering wheel to move gradually away from the center position you want to hold while traveling. On this truck, however, any deviation in the steering wheel center position is automatically corrected, back to the position you want.

### 7 Optimized mast tilt speed

The control valve has a bleed-off circuit to reduce the mast tilting speed, for fine tuning the mast stop position when tilting the mast forward or back.

Mast tilt speeds (Previous models → New models)

Forward: **2.8 → 3.0** seconds

Backward: **1.6 → 3.0** seconds

(FD100-2)



# SAFETY

Quest for safer operation through ergonomics

## Improved safety

### Traveling interlock system

The traveling interlock system prevents the truck from moving if the operator gets out of the operator's seat. A buzzer sounds if the operator leaves his seat while the starter switch is on. After about 3 seconds, the transmission will be locked in neutral and the warning light will come on.



\* The interlock system only shifts the transmission into neutral; it does not engage the brakes. When leaving the truck, always apply the parking brake.

### Neutral start safety mechanism

The neutral start safety mechanism prevents the engine from being started unless the directional control lever is in the neutral position. This prevents the truck from moving abruptly when the starter switch is turned. Also, a neutral indicator has been installed on the instrument panel, to allow the operator to check whether or not the directional control lever is in neutral.

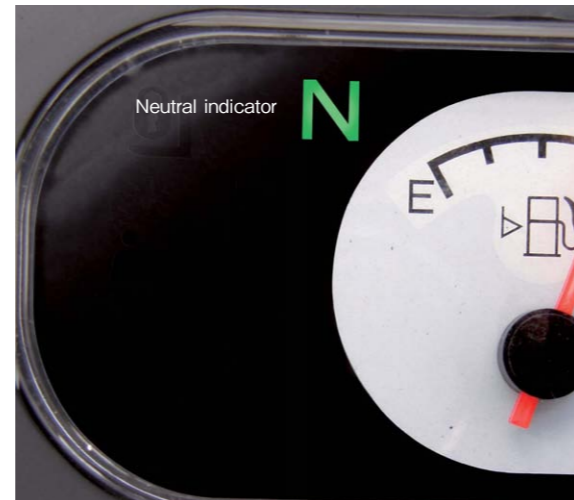

### Wider range of forward visibility

Forward visibility has been improved thanks to the use of a super-wide carriage, and the view of the fork tips from the operator's seat has also been improved substantially.



### Some of the fastest lift speeds in their class

Engine output has been increased with a turbocharger and an intercooler, as well as the direct fuel injection system, to give these trucks some of the fastest lift speeds in their class.

### Overheating prevention

A warning light has been installed to tell the operator that the engine is overheated. If the coolant temperature rises excessively, the engine output is automatically reduced to keep the engine from becoming seriously damaged. (The warning light comes on when the engine has overheated.)

### Safety seat with side supports

The new series is also equipped with a safety seat, a seat belt and side supports. It adjusts easily to the individual operator's weight, reclines, and has fore-and-aft positioning for more operator comfort. It also has a convenient document pocket on the rear of the seat back.



# ECONOMY

Quest for better economy through superb serviceability

## Easier to service

### Rear axle with a built-in cylinder

The rear axle has a built-in steering cylinder. Its simple design with a smaller number of service points contributes to improved ease of servicing.



### Boltless floorboards are easy to remove and reinstall

The front and rear floorboards can be removed and reinstalled easily, without any tools.

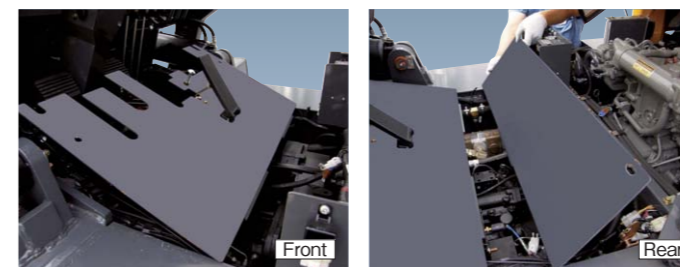

### Engine hood has a gas-spring support

The engine hood has a gas-spring support, so that the operator can open and close the hood easily. The support also has a fail-safe stopper, so the hood won't shut unexpectedly.

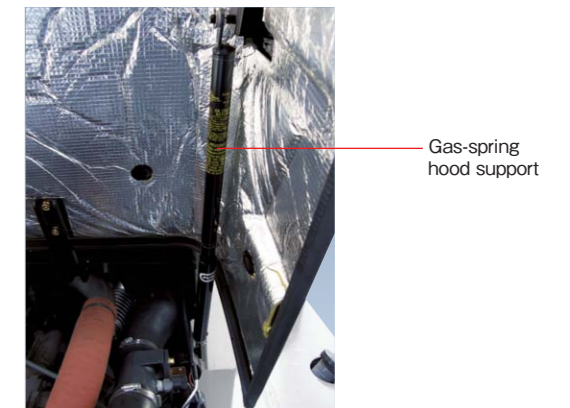

### Pen holder and clipboard

A pen holder and a clipboard to secure papers are provided for your convenience. The clipboard is made of comfortable resin.



### Standard equipment

- Operator's seat
- Horn
- Steering wheel
- Directional control lever
- Parking brake lever
- Brake pedal (inching pedal)
- Brake pedal
- Accelerator pedal
- Turn signal lever and lighting switch
- Lift lever
- Tilt lever
- Starter switch
- Traveling speed selection switch
- Engine warning light
- Fuel level warning light
- Engine preheating indicator light
- Interlock warning light
- Neutral start indicator light
- Fuel level indicator
- Hour meter
- Cooling water temperature gauge
- Engine oil pressure warning light
- Charge warning light

### Optional equipment (for truck body)

- "J" lug tire
- "Unique" tire ("Super Lug")
- "Unique" tire ("Softone")
- Overhead guard-mounted air cleaner (w. precleaner)
- Double-element air cleaner
- Radiator dust screen
- Overhead guard with front windshield (w/ wiper)
- Steel cabin
- Steel cabin (w. air conditioner)
- Car heater
- Different lever arrangement
- Speedometer
- Torque converter oil pressure gauge
- OK monitors
- Rear work light
- Yellow beacon light (140 mm in diameter)
- Yellow beacon light (170 mm in diameter)
- Back-up buzzer (high volume level type)
- Mast-mounted lamps (w. lamp guard)
- Mast tilt gauge
- Fire extinguisher
- Certified inspection specification (incl. speedometer)
- Upright muffler

### Optional equipment for load handling

- Tilt cylinder boot
- Three-valve manifold
- Four-valve manifold
- Three-valve manifold for VM mast piping
- Four-valve manifold for VM mast piping
- Long fork
- Load grab
- Fork extension sleeve
- Fork positioner
- Manual fork positioner
- Hinged fork
- Scoop for hinged fork
- Ram
- Rotating fork
- Side shifter
- Wide carriage
- Full-free mast
- Full-free three-stage mast
- High-Lo mast



- UniCarriers Corporation retains the right to change these products and specifications without incurring any obligation relating to such changes.
- These products and specifications are subject to change without notice.
- Photos and illustrations may slightly differ from the actual trucks.
- Photos and illustrations may or may not include optional equipment and accessories.
- Features and specifications may vary depending on markets.
- Performance data and dimensions are nominal and subject to tolerances.
- Produced in ISO certified factory.